

PULSE CONNECT
Interface module integrated in
digifas™ 7100-STEP
and
digifas™ 7200-STEP



Previous editions

Edition	Comments
05 / 95	First edition, valid from software version 5L30
05/98	Corrections, extensions, valid from software version 6A01

Technical changes improving performance and specifications, may be made without prior notice !

Printed in the Federal Republic of Germany 05/98

Mat.Nr.: 83109

digifas™ is a Regd.TM.No 1549070 of Seidel Corporation

All rights reserved, whether the whole part of the material is concerned, specifically those of translation, reprinting, re-use of illustrations, broadcasting, reproduction by photocopying machine or similar means, and storage in data banks

Contents	Drawing	Page
Contents		3
Safety instructions		4
Directives and standards		5
CE-conformance		5
I General		
I.1 About this manual		7
I.2 "Use as directed" for the PULSE CONNECT interface module		7
I.3 Brief description		8
I.4 Technical data		8
I.5 Front view of digifas™ 7100 / 7200-STEP with functional units		9
I.6 Pin assignments of digifas™ 7100 / 7200-STEP	-A.4.015.4/3,4	9
I.7 Description of signals		10
I.8 Sample traversing profile with signal diagram		11
I.8.1 Interfacing with a stepper motor control		11
I.8.2 Interfacing with a master (slave-operation)	-A.4.015.3/2	11
II Installation and commissioning		
II.1 Installation		13
II.1.1 Connections		13
II.1.2 Wiring diagram of digifas™ 7100 / 7200-STEP	-A.4.015.1/1	14
II.2 commissioning		15
II.2.1 Stepper-motor-drive		15
II.2.1.1 Functional test stepper-motor-drive		15
II.2.1.2 Optimization stepper-motor-drive		16
II.2.2 Master-slave-drive		17
II.2.2.1 Funktional test master-slave-drive		17
II.2.2.2 Optimization master-slave-drive		18
III User software		
III.1 General		19
III.1.1 Description of parameters on CONNECT menu screen		20
III.1.1.1 Kp, P-gain		20
III.1.1.2 Ff, feed forward factor		20
III.1.1.3 t_emerg, minimum deceleration time		20
III.1.1.4 Pulse number		20
III.1.1.5 Counting direction		21
III.1.1.6 Contouring error		21
IV Appendix		
IV.1 CONNECT parameter data sheet		22
IV.2 Index		23

Safety instructions

- ◆ **Warning signs : you must observe the important instructions in the text, which are indicated by the following symbols:**



hazard from electricity
and its effects



general warning
general instruction

- ◆ **Only properly qualified personnel are permitted to perform activities such as transport, installation, commissioning and maintenance. Properly qualified persons are those who are familiar with transport, installation, assembly, commissioning and operation of the products, and who have the appropriate qualifications for their job. The qualified personnel must know and observe the following standards and directives:
IEC 364 and CENELEC HD 384 or DIN VDE 0100
IEC Report 664 or DIN VDE 0110
national accident prevention regulations or VBG 4**
- ◆ **Read the available documentation before carrying out installation and commissioning. Incorrect treatment of the servo amplifier can lead to injury to persons or material damage. It is vital that you keep to the technical data and information on connection requirements nameplate and documentation).**
- ◆ **The servo amplifiers contain electrostatically sensitive components which may be damaged by incorrect handling. Discharge your body before touching the servo amplifier. Avoid contact with highly insulating (artificial fabrics, plastic film etc.). Place the servo amplifier on a conductive surface.**
- ◆ **Do not open the units. Keep all covers and switchgear cabinet doors closed in operation. Otherwise there are deadly hazards with the possibility of severe danger to health or material damage.**
- ◆ **In operation, depending on the degree of enclosure protection, servo amplifiers can have bare components which are live and hot surfaces. Control and power cables can carry a high voltage even when the motor is not rotating.**
- ◆ **Never undo the electrical connections of the servo amplifier when it is live. There is a danger of electric arcing and danger to persons and contact.**
- ◆ **Wait at least two minutes after disconnecting the servo amplifier from the mains supply voltage before touching live sections of the equipment or undoing connections (e.g. contacts, screwed connections). Capacitors can have dangerous voltages present up to two minutes after switching off the supply voltages. To be sure, measure the voltage in the intermediate circuit and wait until it has fallen below 40V.**

Directives and standards

Servo amplifiers are components which are intended to be incorporated into electrical machines and plant.

When the servo amplifiers are incorporated into machines or plant, the intended operation of the amplifiers is forbidden until it has been established that the machine or plant fulfills the requirements of the EC Directive on Machines 89/392/EEC and the EC Directive on EMC 89/336/EEC. EN 60204 and EN 292 must also be observed.

In connection with the Low Voltage Directive 73/23/EEC, the harmonized standards of the EN 50178 series are applied to the servo amplifiers, together with EN 60439-1, EN 60146 and EN 60204.

The manufacturer of the machine or plant is responsible for ensuring that the machine or plant meets the limits which are laid down by the EMC regulations. Advice on the correct installation for EMC – such as shielding, grounding, arrangement of filters, treatment of connectors and laying out the cabling – is included in this documentation..

-conformance

Conformance to the following directives is mandatory for the supply of servo amplifiers within the European Community:

since 1 January 1996	:	EC EMC Directive 89/336/EEC
since 1 January 1997	:	EC Low-Voltage Directive 73/23/EEC

The correct installation for EMC is shown in the installation instructions for the servo amplifier. These instructions also show the components which are required (cables, mains filters etc.)

Any divergence from the configuration and installation which is described in the documentation means that you will be responsible for the performance of new measurements to ensure that the regulatory requirements are met.

Only on condition that the components which we have specified are used and the installation rules are observed can we guarantee that the servo amplifier conforms to the following standards for industrial areas:

EC EMC Directive	89/336/EEC
EC Low Voltage Directive	73/23/EEC

This page was deliberately left blank

I General

I.1 About this manual

This manual describes the wiring, commissioning and range of functions of the interface module PULSE CONNECT. It is part of the complete documentation of the digifas™ 7100 and digifas™ 7200 series of digital servo amplifiers.

The manual is divided into 4 chapters :

- Chapter 1: General information, brief description, technical data
- Chapter 2: Installation and commissioning
- Chapter 3: Description of the user software (CONNECT menu screen) with all its functions and parameters
- Chapter 4: Appendix and form for parameter data

Other parts of the complete documentation for the digifas™ 7100 and digifas™ 7200 series of digital servo amplifiers:

Title	Manufacturer	Order No.
Operating manual for BS7200 user software	Seidel	83107
Operating manual for digifas™ 7200	Seidel	83003
Operating manual for digifas™ 7100	Seidel	83498

This manual is intended for the use of qualified personnel with the following qualifications:



Installation : Electrically trained personnel
Commissioning : Personnel trained in control technology

We offer training and familiarization courses on request.

I.2 “Use as directed” for the PULSE CONNECT interface module

The PULSE CONNECT interface module is permanently built into digital servo amplifiers of the digifas™ 7100-STEP and digifas™ 7200-STEP series. These servo amplifiers are to be used **only** on three-phase 400V industrial earthed mains supplies. The digifas™ 7100-SPS and digifas™ 7200-SPS series of servo amplifiers are **exclusively** intended for closed-loop driving of brushless synchronous servomotors from the 6SM series. The PULSE CONNECT interface module is used only to connect the servo amplifier to a stepper motor control or a master with an output compatible to an incremental encoder. The servo amplifiers are components which are installed in electrical equipment or machines, and can only be commissioned as integral components of such equipment or machines. You must prepare a hazard analysis before commissioning the equipment or machine.



Only on condition that the components which we have specified are used and the installation rules are observed can we guarantee that the servo amplifier conforms to the following standards for industrial areas:

EC EMC Directive	89/336/EEC
EC Low Voltage Directive	73/23/EEC

I.3 Brief description

The PULSE CONNECT interface module is designed to connect a digital servo amplifier of the series digifas™ 7100 or digifas™ 7200 to a stepper motor controller or to combine two or more digital servo amplifiers (master-slave-operation).

- Interfacing of the digital controller with a **stepper motor controller** by:
 - Parameterization in the PC-AT with the user-software BS7200
 - Step count adjustable (can be adjusted to suit all controls)
 - Control signal level +24V for function selection
 - +24V for pulse or direction signals
 - or RS422 for pulse or direction signals
 - adjustable contouring error evaluation
 - standstill signal
- or — **Incremental encoder input** for slave-controller operation with:
 - Parameterization in the PC-AT with the user-software BS7200
 - Pulse number per turn is adjustable
 - Single, double, or 4x evaluation selectable
 - Control signal level +5V for track A and track B
 - adjustable contouring error evaluation
 - standstill signal



To prevent the position output of the (analog) master-controller from overload, do not connect more than two slave-amplifiers.

I.4 Technical data

Technical data PULSE CONNECT			
Control inputs			
X7/1...2	pulse +/-	24V/12mA , (18...36V), LOW = 0...7V, HIGH = 12...36V For connection to a 24V stepper control with 24V signals Pulse is counted on the rising edge	
X7/3...4	direction +/-	24V/12mA , (18...36V), LOW = 0...7V, HIGH = 12...36V For connection to a 24V stepper control with 24V signals Count direction: positive with LOW level, negative with HIGH Changeover only possible when pulse = LOW	
X7/5...6	track A +/- (pulse +/-)	5V/15mA , (4.5...5.5V), LOW = 0...2V, HIGH = 2.5...5V For connection to an incremental encoder or to a stepper motor controller with RS422 signals	
X7/7...8	track B +/- (direction +/-)	5V/15mA , (4.5...5.5V), LOW = 0...2V, HIGH = 2.5...5V For connection to an incremental encoder or to a stepper motor controller with RS422 signals	
X7/9...10	Y1 / Y2	24V/12mA , (18...36V), LOW = 0...7V, HIGH = 12...36V Coding of the "Connect" function	
		Function	Y1 Y2 Pulse no./3500rpm
		24V stepper or RS422	0 0 max. 2048 pulse/turn
		Incremental single	1 0 max. 2048 pulse/turn
		Incremental double	0 1 max. 1024 pulse/turn
		Incremental 4 x	1 1 max. 512 pulse/turn
X7/12	0V-PLC	Ground reference for inputs X7/9...10	
Connection			
Plug : MiniCombicon, 12-pole, coded on PIN 1			
Cable: length max. 50m , 4 x 2 x 0.5mm ² , twisted pair			
max. settable motor speed		6000rpm	
max. pulse frequency		120kHz	

I.5 Front view of digifas™ 7100 / 7200-STEP with functional units

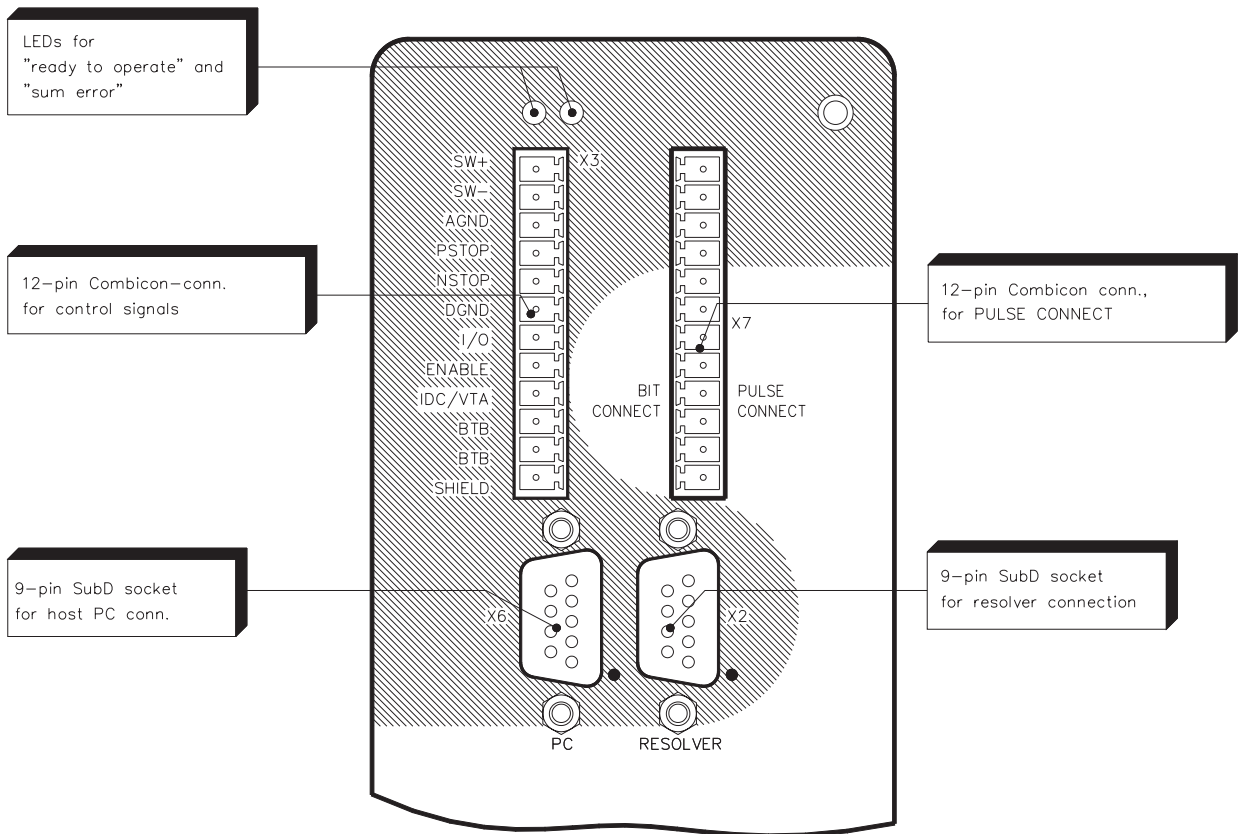

I.6 Pin assignments of digifas™ 7100 / 7200-STEP

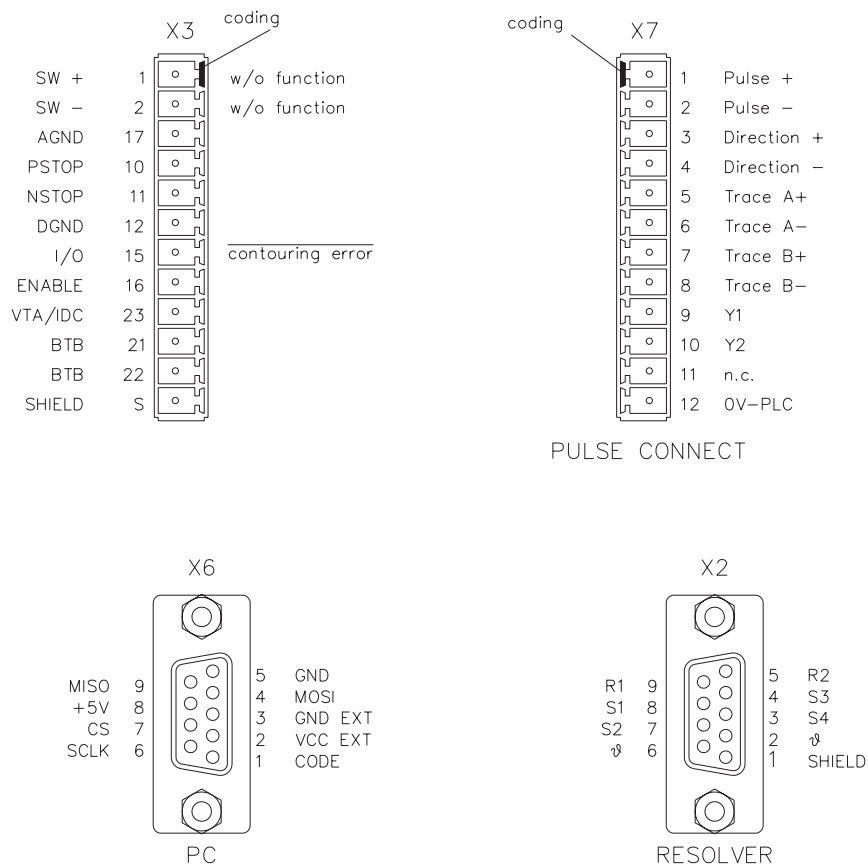

I.7 Description of signals

Decoupling : All inputs to plug X7 are electrically isolated from the amplifier by optocouplers.

Level definition: see Chapter I.4

Terminals X3/15: output with the function “contouring error” or “standstill”.
 You can choose the desired function on the “General” menu screen (see also operating manual for BS7200 user software). All other functions in this menu point are inactive.

Contouring error: Signal to controller that the load has left the preselected (LOW-active) contouring error window and that the amplifier has then performed an emergency braking operation. The position controller remains disabled then until the signal is cleared by switching the 25V supply off and on again.

Standstill : Signal to controller that the speed is below 10rpm. This signal is cleared as soon as the speed has increased above this value.

Selection Y1/Y2: “Connect” function coding, sensing always active. The inputs must be hard-wired. **Changeover only permitted when controller is switched off.**

Terminal X7/9..10	Function	Y1	Y2	pulse count/3500 rpm
	24 V stepper or RS422	0	0	max. 2048 pulse/turn
	Incremental single	1	0	max. 2048 pulse/turn
	Incremental double	0	1	max. 1024 pulse/turn
	Incremental 4 x	1	1	max. 512 pulse/turn

The analogue setpoint input SW+/- (terminals X3/1...2) is inoperative.

For all other inputs and outputs see digifas™ 7100 / 7200 manuals.

I.8 Sample traversing profile with signal diagram

I.8.1 Interfacing with a stepper motor control

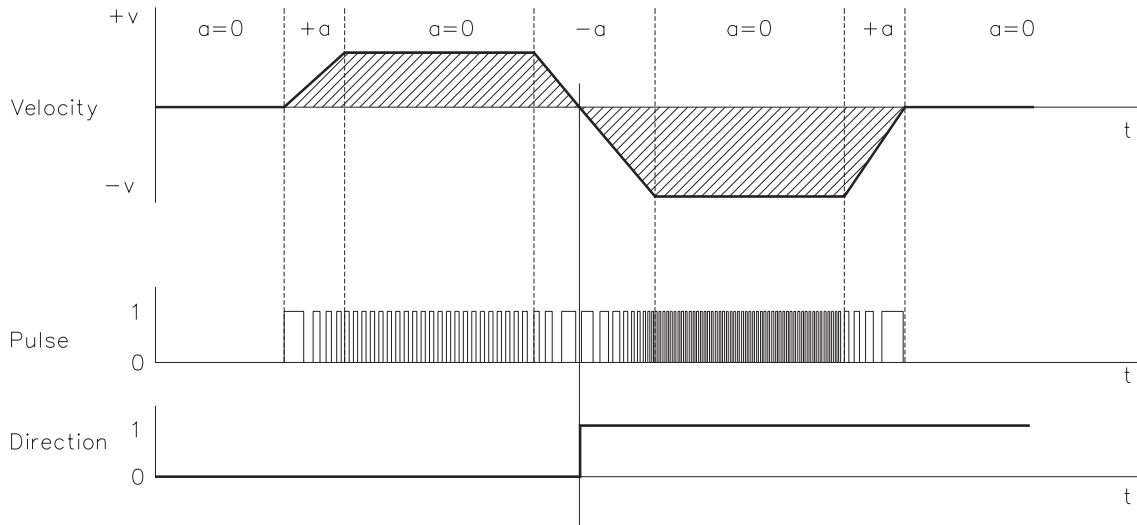

Derivatives:

- Distance traversed s — no. of pulses
- Velocity v — pulse frequency
- Acceleration a — change of pulse frequency

I.8.2 Interfacing with a master (slave-operation)

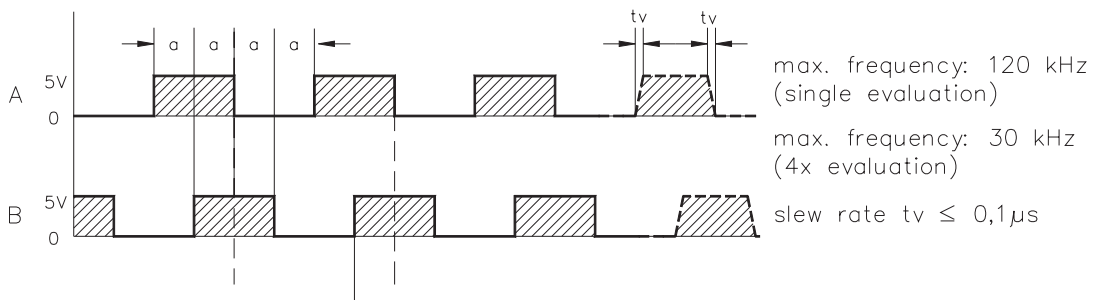

This page was deliberately left blank

II Installation and commissioning

II.1 Installation



Ensure that the switchgear cabinet is properly isolated (barrier, warning signs etc.). The individual supply voltages will only be turned on again during commissioning.

Residual charge in the capacitors can still have a dangerous level even several minutes after switching off the mains supply. Measure the voltage in the DC-link circuit, and wait until it has fallen below 40V.

Even when the motor is not rotating, the control and power leads may still be live.

Electronic equipment is not proof against failure. The user is responsible for making sure that, in the event of a failure of the servo amplifier, the drive is brought to a safe state for personnel and for the machinery, for instance by using a mechanical brake.

Drives with servo amplifiers and CONNECT modules are remote-controlled machines. They can start to move at any time, without warning. Bring this to the attention of the operating and service personnel by using appropriate warning signs.

Take appropriate safety measures to ensure that an unintended starting of the machine cannot lead to dangerous situations for personnel or machinery. Software limit switches cannot replace the hardware limit switches on the machine.



Install the servo amplifier as described in the installation manual for digifas™ 7100 or digifas™ 7200 respectively. The wiring for the analog setpoint input and the positioning interface in accordance with the installation manual does not apply.

Use whichever wiring diagram is valid for the amplifier concerned, in Chap. II.1.2 of this manual, for the connection of the CONNECT interface.

Always install and wire up the equipment in a de-energized state. Neither the mains power supply, nor the 25V auxiliary supply, nor the operating voltage of any other equipment which is connected may be switched on. Never loosen the electrical connections to the servo amplifier while it is live. This could result in destruction of the electronics.

Because of the internal representation of the position-control parameters, the position control can only be operated if the final limit speed of the drive is no more than 6000 revs/min. All information about resolution, incremental step size, positioning accuracy etc. refers to calculated values. Non-linearities in the mechanism (backlash, elasticity etc.) are not taken into account.

If it is necessary to alter the final limit speed of the motor, then all the position control and motion block parameters which were previously entered must be adjusted.

II.1.1 Connections

We recommend the following line cross-sections in compliance with EN 60204:

Mains connection, motor connection, digital control lines	refer to digifas™ 7100/ 7200 installation manuals
PULSE CONNECT (X7)	up to 50m long, 4 x 2 x 0,5mm ² , twisted pairs Cable type: Ölflex

II.1.2 Wiring diagram of digifas™ 7100 / 7200-STEP

Motor connections and power input see installation instructions in the controller manual.

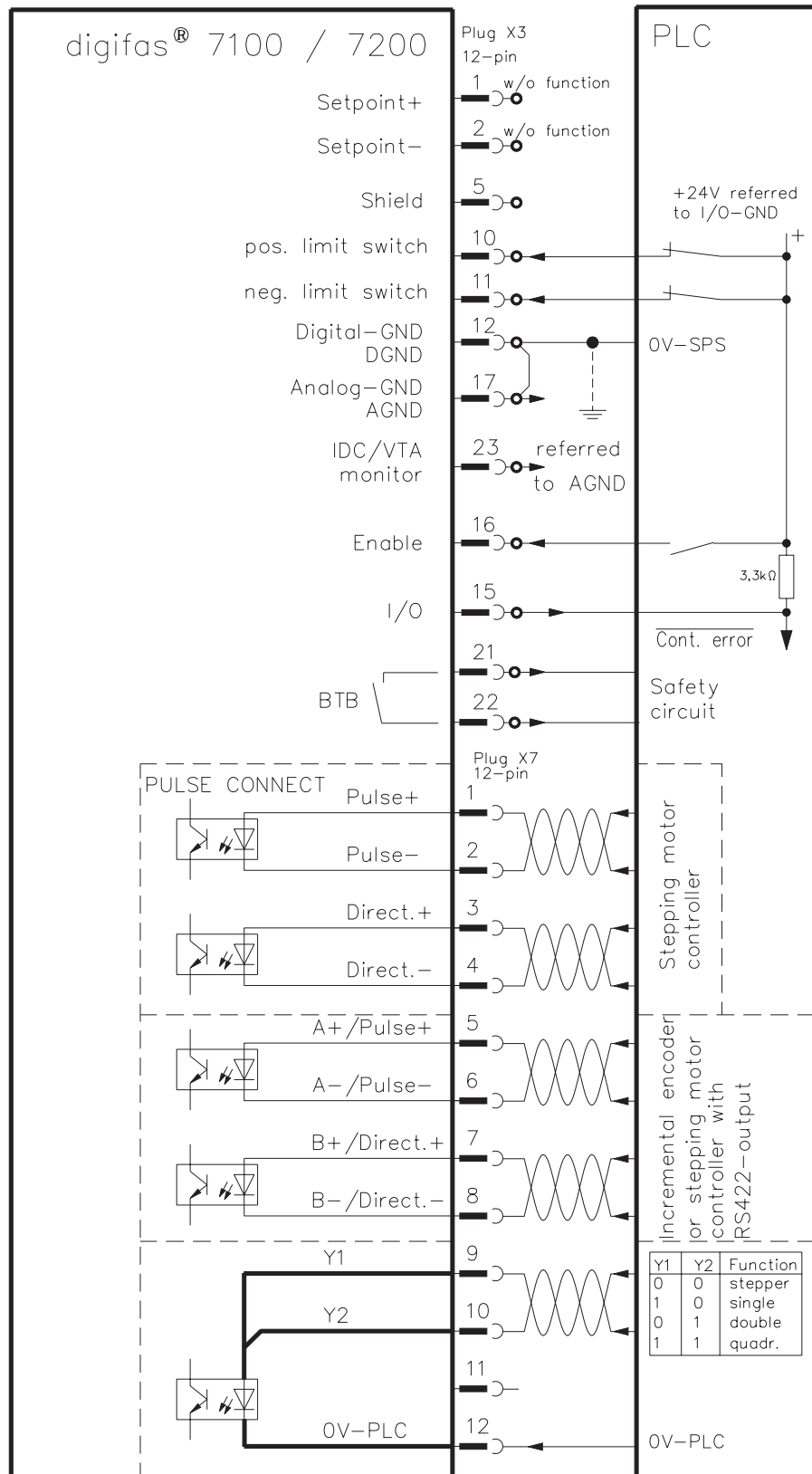

II.2 commissioning

II.2.1 Stepper-motor-drive



The parameter values specified below for testing the correct functioning of the position controller do not apply to all systems and may in fact be hazardous to some systems. It is therefore imperative that you check the values for correctness. If you have to change values, please bear in mind that this is only a functional test. Set absolutely safe values which cannot cause damage to the machine under any circumstances.

II.2.1.1 Functional test stepper-motor-drive

1. — Optimize the speed controller using the “Reversing mode” service function
2. — Shut down the drives and disable the enable signal for the amplifier
3. — Select the CONNECT menu screen in the user software and set the position controller parameters (after checking to see if the system permits the values) as follows:

Parameter	Setting	Parameter	Setting
Kp	0,5...1	pulse count	pulses / motor turn
Ff	1	count direction	according to the application
t_emerg	Min. Deceleration time permitted by the system	contouring error	window larger than required by the application

- 4.— Switch on the drives, switch on the enable signal for the amplifier (“Accept” pushbutton)
5. — Use the stepper motor control to traverse in both directions at low speeds in joggin mode.

II.2.1.2 Optimization stepper-motor-drive



The current, speed and position controllers function as a classic cascade control. A correct, i.e. stiff, setting of the inner speed control is therefore a prerequisite for optimizing the position controller. All parameters concerning the speed controller, including acceleration and deceleration ramps, remain active.

1. — Carry out jogging alternately in both directions.
2. — Alter the Ff-factor until the “contouring error” display (actual value display in the Connect screen) during acceleration reaches a minimum.

Tip for the user:

If the direction of rotation is positive, then the contouring error should be positive, since the drive will be lagging slightly (increase Ff).

If the contouring error is negative (reduce Ff) then the drive is leading the setpoint (oversteering). The same logic applies to the negative direction of rotation.

3. — Repeat points 1 and 2 in several steps with different speeds and different acceleration and braking times, until the desired speed under load and the required acceleration and deceleration times are achieved.
Depending on the mass to be moved, it may be impossible to reach the desired speed under load using only the Ff-factor. In this case the Kp-factor must be increased slightly.
4. — Increase the Kp-factor until the controller just begins to oscillate, and then reduce it a bit. An oscilloscope can be used to observe the transient response during acceleration at the speed monitor (VTA) of the controller, and the Kp-factor adjusted if necessary.
5. — Finally, set the following parameters according to the application:
Contouring-error window and t_emerg



Warning :

If the final limit speed of the motor has to be changed, then all the position control parameters which were previously entered must be adjusted !

If Irms and / or Ipeak are changed, after the position controller has been optimized, then Kp and Ff must be adjusted !

II.2.2 Master-slave-drive



The parameter values specified below for testing the correct functioning of the position controller do not apply to all systems and may in fact be hazardous to some systems. It is therefore imperative that you check the values for correctness. If you have to change values, please bear in mind that this is only a functional test. Set absolutely safe values which cannot cause damage to the machine under any circumstances.

II.2.2.1 Funktional test master-slave-drive

1. — Optimize the speed controller by using the “Reversing mode” service function
- 2.— Switch off the drives, switch off the enable signal for the amplifier (“Accept” pushbutton)
3. — Select the CONNECT menu screen in the user software and set the position controller parameters as follows (after checking that these values are permissible for this system):

Parameter	Setting	Parameter	Setting
Kp	0.5 ... 1	pulse count	pulses / motor turn
Ff	1	count direction	according to the application
t_emerg	Min. deceleration time permitted by the system	contouring error	window larger than required by the application

- 4.— Switch on the drives, switch on the enable signal for the amplifier (“Accept” pushbutton)
5. — Traverse the master which is connected in both directions at low speeds in jogging mode. The slave must follow the master.

II.2.2.2 Optimization master-slave-drive



The current, speed and position controllers function as a classic cascade control. A correct, i.e. stiff, setting of the inner speed control is therefore a prerequisite for optimizing the position controller. All parameters concerning the speed controller, including acceleration and deceleration ramps, remain active.

1. — Carry out jogging, with the master controller, alternately in both directions.
2. — Alter the Ff-factor until the “contouring error” display of the slave controller (actual value display in the Connect screen) during acceleration reaches a minimum

Tip for the user:

If the direction of rotation is positive, then the contouring error should be positive, since the drive will be lagging slightly (increase Ff).

If the contouring error is negative (reduce Ff) then the drive is leading the setpoint (oversteering). The same logic applies to the negative direction of rotation.

3. — Repeat points 1 and 2 in several steps with different speeds and different acceleration and braking times, until the desired speed under load and the required acceleration and deceleration times are achieved.
Depending on the mass to be moved, it may be impossible to reach the desired speed under load using only the Ff-factor. In this case the Kp-factor must be increased slightly.
4. — Increase the Kp-factor until the controller just begins to oscillate, and then reduce it a bit. An oscilloscope can be used to observe the transient response during acceleration at the speed monitor (VTA) of the controller, and the Kp-factor adjusted if necessary.
5. — Finally, set the following parameters according to the application:
Contouring-error window and t_emerg



Warning :

If the final limit speed of the motor has to be changed, then all the position control parameters which were previously entered must be adjusted !

If Irms and / or Ipeak are changed, after the position controller has been optimized, then Kp and Ff must be adjusted !

III User software

III.1 General

The digital servo amplifiers of the digifas™ 7100/7200 series have to be adapted to the operating characteristics of your machine. The BS7200 user software is a user-friendly means of parameterizing the two digifas™ 7100 and 7200 regulator types.



Only the part of the BS7200 user software relevant to the BIT CONNECT interface module is described in this section. Instructions for handling the software and parameters of the current regulator speed controller are described in the BS7200 operating manual.

The “Connect” menu item is displayed in the menu line of the user software. You will find all the parameters relevant to setting the position controller under this menu item.

The following **values** are displayed in online mode on the CONNECT menu screen:

s_act	current position of load	[pulses]
S_set	strived position of load	[pulses]
s_fault	current contouring error of load	[pulses]
v_act	current speed of load	[pulses/s]
v_max	maximum number of pulses per second, which can be processed (static display, depending on the entries)	[pulses/s]

III.1.1 Description of parameters on CONNECT menu screen

The parameters can be printed out and saved.

III.1.1.1 Kp, P-gain

Defines the proportional gain of the position controller. Setting range: 0 to 8

Effects: Value too low — Too much runout, drive runs too softly
Value too high — Drive oscillates

III.1.1.2 Ff, feed forward factor

Defines the speed feed forward factor of the position controller. The feed forward factor serves to relieve the P controller. The better the Ff factor, the better the dynamic range of the P controller can be utilized. The most favourable setting (usually 1.0) depends on external factors such as friction, dynamic resistance and rigidity.

Setting range: 0 to 2

Effects: Value too low — Dynamic range of the P controller is limited. Drive lags
Value too high — Dynamic range of the P controller is limited. Drive leads

III.1.1.3 t_{emerg}, minimum deceleration time

Fixes the limiting value for the braking deceleration time. On leaving the contouring-error window the drive will be braked to a stop within the maximum deceleration time, provided that sufficient electrical energy is available. Setting range: 10 ... 2550 ms

Effects: Value too low — the mechanism of the machine and/or the drive may be damaged
Value too high — the drive cannot brake quickly enough

III.1.1.4 Pulse number

The pulse number can only be changed when the controller is switched off.

When connected to stepper motor control (Y1=Y2=0):

— Adjust to the number of pulses per motor turn which are produced by the controller

When connected to an incremental encoder (Y1 v Y2 ≠ 0):

— The number of increments per motor turn, produced by an incremental encoder or the ROD-interface of the master controller.

The selection of single, double or quadruple evaluation (Y1 and Y2, see Chapter I.9) is automatically taken into account by the program.

Setting range: 200 ... 512 (1024, 2048) pulses/turn

Pulse no.[pulses/turn]	Y-function select	Final speed [rpm]	Comments
512	4 x	3500	The final speed is doubled with 2x evaluation, quadrupled with single evaluation, up to the limit of 6000 rpm
1024	4 x	1750	
2048	4 x	870	

Effects: Value too low — the required physical value has not been reached
Value too high — the required physical value is exceeded

III.1.1.5 Counting direction

Defines the counting direction for the positional values. Selection: positive / negative

Effects:

positive	—	with positive direction of rotation (clockwise when looking at the motor shaft) increasing position values when the direction signal = 0 or track A before track B
negative	—	with negative direction of rotation (counter-clockwise when looking at the motor shaft) increasing position values when the direction signal = 0 or track A before track B

In both cases the actual position counts upwards!

III.1.1.6 Contouring error

The contouring error is the maximum difference between the actual and set positional values which is permitted to occur during the process. The entry for contouring error is interpreted as a +/- window. If the contouring error which appears is within this window it will be recognized and corrected by the position controller, and **no pulses will be lost**. If the drive leaves the window the position controller generates an error message and brakes the drive with the emergency deceleration.

Setting range: 0 ... 49 % of the preset pulse number

Effects:

Value too low	—	the acceleration process is terminated
Value too high	—	the contouring error is not recognized

IV Appendix

IV.1 CONNECT parameter data sheet

The default values given below are only for the preliminary commissioning.
 Check all the values according to the requirements of your system.
 See also Chapter III

Display text	Dimension	min	max	Default	actual value
Kp	---	0	8	1	
Ff	---	0	2	1	
t_emerg	ms	10	2550	50	
Pulse no.	pulses/turn	200	2050	500	
Counting direction	---	positive	negative	positive	
Contouring error	pulses	0	49 % pulse no.	200	

Customer _____ Cabinet no. _____ Equipment no. _____

Place, date _____ Signature _____

IV.2 Index

	<u>Text</u>	<u>Page</u>
B	Brief description	8
C	CE-conformance	5
	Commissioning	
	Master-slave-drive	17
	Stepper-motor-drive	15
	Complete documentation	7
	Connections	13
	Contents	3
D	Default values	22
	Description of parameters	
	Contouring error	21
	Counting direction	21
	Ff	20
	Kp.	20
	Pulse number.	20
	t_emerg.	20
	Description of signals	
	Contouring error	10
	Decoupling	10
	Standstill	10
	Directives and standards	5
F	Front view.	9
I	Installation	13
L	Line cross-sections	13
P	Parameter data sheet.	22
	Pin assignments	9
S	Safety instructions	4
	Sample traversing profile	
	Slave-operation.	11
	Stepper motor control.	11
T	Technical data	8
U	Use as directed	7
	User software.	19
W	Wiring diagram	14

Vertrieb und Service / Sales and Service / Agence et Services

Bundesrepublik Deutschland/ Germany/Allemagne

Seidel Servo Drives GmbH
Verkaufsniederlassung Nord
Dasselsbrucher Str. 49a
D-29227 Celle
Tel.: +49(0)5141 - 98 10 40
Fax: +49(0)5141 - 98 10 41

Seidel Servo Drives GmbH
Verkaufsniederlassung West
Wacholderstr. 40-42
D-40489 Düsseldorf
Tel.: +49(0)203 - 99 79 - 180
Fax: +49(0)203 - 99 79 - 118

Seidel Servo Drives GmbH
Verkaufsniederlassung Süd-West
Bruchsaler Str. 3
D-76646 Bruchsal-Untergrombach
Tel.: +49(0)7257 - 9 23 07
Fax: +49(0)7257 - 9 23 08

Seidel Servo Drives GmbH
Verkaufsniederlassung Süd-Ost
Viehmarktstr. 7a
D-82256 Fürstenfeldbruck
Tel.: +49(0)8141 - 34 90 94
Fax: +49(0)8141 - 34 90 95

Servo-Dyn
Technik GmbH
Münzgasse 10
D-01067 Dresden
Tel.: +49(0)351 - 49 05 793
Fax: +49(0)351 - 49 05 794

Dänemark/ Denmark/Danemark

DIGIMATIC
Ormhøjgaardvej 12-14
DK-8700 Horsens
Tel.: +45 - 76 26 12 00
Fax: +45 - 76 26 12 12

Finnland/ Finland/Finlande

Drivematic OY
Hevosenkentä 4
FIN-28430 Pori
Tel.: +358 - 2 - 52 99 600
Fax: +358 - 2 - 52 99 610

Frankreich/ France/France

Seidel Servo Drives GmbH
Parc technologique St.Jacques
2 rue Pierre et Marie Curie
F-54320 Maxéville
Tel.: +33(0)3 83 95 44 80
Fax: +33(0)3 83 95 44 81

Großbritannien/ Great Britain/Royaume-Uni

Kollmorgen
PO Box 147, KEIGHLEY
West Yorkshire, BD21 3XE
Tel.: +44(0)15 35 - 60 76 88
Fax: +44(0)15 35 - 68 05 20
Heason Technologies Group
Claremont Lodge
Fontwell Avenue
Eastergate Chichester PO20 6RY
Tel.: +44(0)12 43 - 54 54 00
Fax: +44(0)12 43 - 54 45 90

Italien/ Italy/Italie

M.C.A. s.r.l.
Via f. Turati 1
I-20016 Pero (Mi)
Tel.: +39(0)2 - 33 91 04 50
Fax: +39(0)2 - 33 90 85 8

Niederlande/ Netherlands/Pays-Bas

Dynamic Drives
Jan van der Heydenstraat 24a
NL-2665 JA Bleiswijk
Tel.: +31(0)10 - 52 15 490
Fax: +31(0)10 - 52 18 994

Schweden/ Sweden/Suède

S D T AB
SE-25467 Helsingborg
Tel.: +46(0)42 - 380 800
Fax: +46(0)42 - 380 813
Stockholm
SE-12030 Stockholm
Tel.: +46(0)8 - 640 77 30
Fax: +46(0)8 - 641 09 15
Göteborg
SE-42671 Västra Frölunda
Tel.: +46(0)31 - 69 62 60
Fax: +46(0)31 - 69 62 69

Schweiz/ Switzerland/Suisse

Seidel Servo Drives GmbH
Eggbühlstr. 14
CH-8050 Zürich
Tel.: +41(0)1 - 300 29 65
Fax: +41(0)1 - 300 29 66

Spanien/ Spain/Espagne

Comercial BROTOMATIC, S.L.
San Miguel de Acha, 2 Pab.3
E-01010 Vitoria
Tel.: +34 945 - 24 94 11
Fax: +34 945 - 22 78 32

Systempartner / System partners / Partenaires du syst me

Bundesrepublik Deutschland/ Germany/Allemagne

Werner P. Hermes
Ingenieurbüro
Turmstr. 23
40750 Langenfeld
Tel.: +49(0)212 - 65 10 55
Fax: +49(0)212 - 65 10 57

EAT GmbH
Elektronische Antriebstechnik
Abrichstr. 19
79108 Freiburg
Tel.: +49(0)761 - 13 03 50
Fax: +49(0)761 - 13 03 555

IBK Ingenieurbüro Keßler GmbH
Dachmisser Str. 10
21394 Kirchgellersen
Tel.: +49(0)4135 - 12 88
Fax: +49(0)4135 - 14 33

Großbritannien/ Great Britain/Royaume-Uni

Motor Technology Ltd.
Unit 1
Chadkirk Industrial Estate
Offerspool Road
Romiley, Stockport
GB-Cheshire SK6 3LE
Tel.: +44(0)161 - 42 73 641
Fax: +44(0)161 - 42 71 306

Schweiz/Switzerland/Suisse

Bobry Servo Electronic AG
Zentralstr. 6
CH-6030 Ebikon
Tel.: +41(0)41 - 440 - 77 22
Fax: +41(0)41 - 440 - 69 43

Frankreich/France/France

Transtechnik Servomécanismes
Z.A. Ahuy Suzon
17, Rue des Grandes Varennes
F-21121 AHUY
Tel.: +33(0)3 - 80 55 69 41
Fax: +33(0)3 - 80 53 93 63

Niederlande/ Netherlands/Pays-Bas

Kiwiet
Ingenieurbüro
Helenaveenseweg 35
NL-5985 NK Panningen (Grashoek)
Tel.: +31(0)77 - 30 76 661
Fax: +31(0)77 - 30 76 646

Italien/Italy/Italie

Servo Tecnica
Viale Lombardia 20
I-20095 Cusano Milanino (MI)
Tel.: +39(0)2 - 66 42 01
Fax: +39(0)2 - 66 40 10 20

Australien/Australia/Australie

FCR Motion Technology PTY. Ltd.
23 Mac Arthurs Road
Altona North, 3025
Melbourne/Australia
Tel.: +61 393 99 15 11
Fax: +61 393 99 14 31

Seidel Servo Drives GmbH

Hausanschrift

Wacholderstr. 40-42
D - 40489 Düsseldorf
Tel.: +49(0)203 - 99 79 - 0
Fax: +49(0)203 - 99 79 - 155
Internet : <http://www.seidelservodrives.de>

Postanschrift

Postfach 34 01 61
D-40440 Düsseldorf

Kollmorgen

201 Rock Road
Radford, VA 24141
Tel.: +1 540 - 639 - 24 95
Fax: +1 540 - 731 - 08 47
Internet : <http://www.kollmorgen.com>